

# OTM Series Data Sheet



## Specific Technical Data

Model	OTM3 / OTM3M / OTM3S			OTM3A			OTM3SA		
	-03	-10	-20	-20	-35	-50	-03	-10	-20
Measuring range (mm)	3	10	20	20	35	50	3	10	20
Standoff (mm)	20	44	59	85	110	140	20	44	59
Resolution (µm)	0,3	1	2	2	3,5	5	0,3 / mV	1,0 / mV	2,0 / mV
Repeatability (µm) *1)	1,5	5	10	10	18	25	1,5	5	10
Local meas. uncertainty (µm) *2)	7,5	25	50	20	35	50	7,5	25	50
Linearity (%) *3)	0,2 % of measuring range						Customer linearization		
Data output	digital / analog (optional)						analog		
Threshold frequency	200 Hz, with option /F: 2 kHz						0,1 / 1,0 / 10 kHz		
Max. data rate	3.500 points/sec.						analog output		
Spot size (µm) *4)	40	60	90	100	120	140	40	60	90

## General Technical Data

All models	OTM3	OTM3M	OTM3S	OTM3A	OTM3SA
Working temperature range	+18°C to +22°C				
Operating temperature range	+10°C to +40°C				
Storage temperature range	-10°C to +70°C				
Air humidity	max. 80% (non-condensing)				
Laser safety	Class II or 3B (wavelength 680 nm)				
Speed of adaption to reflection	< 1 ms				
Threshold angle for detection of inclined surfaces *5)	80°				
Threshold angle for precision specifications *5)	60°				
Max. cable length (sensor head to controller)	50m (3m for analog cable OTM3S / OTM3SA)				

## Dimensions and Weight all dimensions in mm (1mm = 39,37 x 0,001")

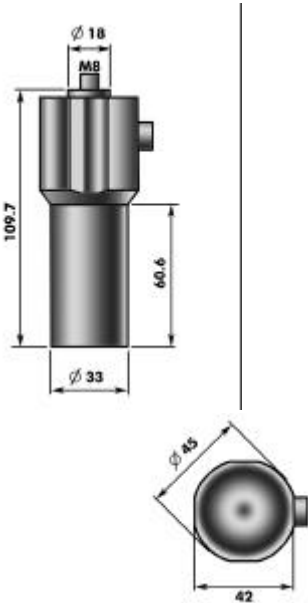
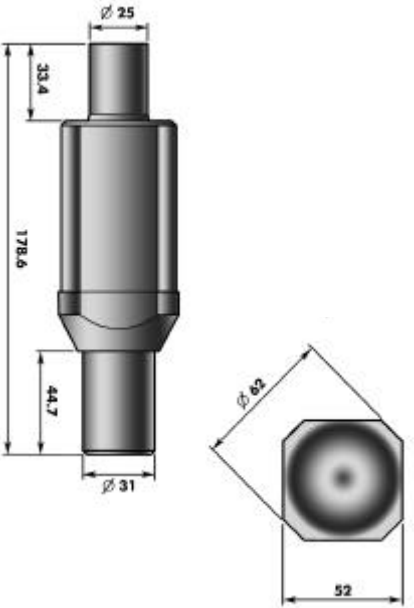
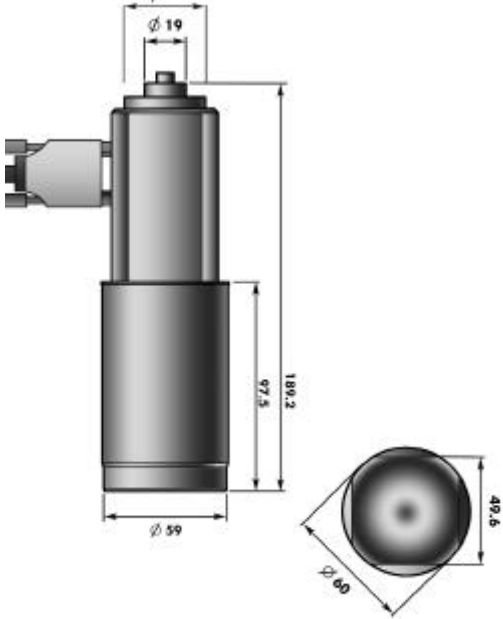
OTM3S/OTM3SA	OTM3 / OTM3M	OTM3A
		
weight 200g	weight 350g	weight 750g

\*1) According to DIN 32877 repeat accuracy without movement of sensor relative to part (electrical noise). This value is 3x higher with option /F.

\*2) According to DIN 32877 repeat accuracy with lateral movement of sensor relative to part within 3x spot size (optical noise does not include electrical noise). This value does not change with option /F

\*3) According to DIN 32877 full range linearity error on calibration surface (does not include electrical or optical noise) in % of measuring range.

\*4) In center of measurement range

\*5) Dependent on measured surface, figures based on reference surface

\*6) Adapter adjustable for orientation of connector. This dimension can vary up to 2mm.

NB All accuracy values are for standard configuration (F3), measured on a digital interface with sufficient reflection from diffuse reflecting non volume scattering surface (intensity > 150).

## Controller Data

	Desktop / Rack mount	PCI-Card
Power Supply	24 Volt $\pm$ 10% 0,5 A incl. sensor head	from PC 5 V $\pm$ 5% 1,7 A incl. sensor head
I/O's	<ul style="list-style-type: none"> <li>• sensor interface</li> <li>• RS-232</li> <li>• 32-bit TTL parallel output (for distance, intensity and status information)</li> <li>• status port (open collector status and trigger/sync)</li> <li>• TP2 compatible trigger signal</li> </ul>	<ul style="list-style-type: none"> <li>• sensor interface</li> <li>• 32-bit TTL parallel output (for distance, intensity and status information)</li> <li>• status port (open collector status and trigger/sync)</li> <li>• PCI-Bus (for distance, intensity and status information)</li> </ul>
Mounting	<ul style="list-style-type: none"> <li>• desktop or in 19" rack (with optional brackets)</li> </ul>	<ul style="list-style-type: none"> <li>• PCI slot</li> </ul>
Weight	2500 g	250 g
Dimensions (LxWxH) mm	290 x 220 x 88,8	

## Interfaces

	OTM3	OTM3M	OTM3S	OTM3A	OTM3SA
Mech. probe interface	M8 thread	Renishaw Autojoint	M8 thread	M8 thread	M8 thread
Electr. probe interface	HDD plug	Renishaw Autojoint	12 pin HR10 (HRS)	HDD plug	12 pin HR10

## Options

Part No.	Description	Remarks
/C	Collision protection	
/F	Fast: 10x higher cut-off frequency	Increases repeatability by factor 3. For OTM3A/OTM3B: Recommended only after consultation with W&B
/L	Low laser power, laser class 2 ( $P_0 < 1$ mW; max power $< 2$ mW)	Not recommended for: OTM3A/OTM3B
/H	High power laser, laser class 3B ( $P_0 < 4$ mW; max power $< 8$ mW)	See also operator's manual regarding laser protection classes according to EN 60825-1 and -21 CFR sub-chapter 3.
/H <sup>2</sup>	High power laser, laser class 3B ( $P_0 < 8$ mW; max power $< 16$ mW)	See also operator's manual regarding laser protection classes according to EN 60825-1 and -21 CFR sub-chapter 3.
/P	Pseudo measurement identification	Controlled by DIP-switch
/Sxx	Special linearization	Sensor optimization for customer specific material
/Xxx	Customer specific elec /mech sensor interface	

## Accessories

Part No.	Sensor Accessories
OTM3-V020	lens attachment for OTM3-10 or OTM3-20 reduces measuring range and increases resolution
OTM3A-V020	lens attachment for OTM3A-50 reduces measuring range to 20 mm and increases resolution to 2 $\mu$ m
OTM3A-V035	lens attachment for OTM3A-50 reduces measuring range to 35 mm and increases resolution to 3,5 $\mu$ m
OTM3A-PGP	protective glass for OTM3A
OTM3-P-SC	standard cables in varying lengths or customer specific cables
	<b>Application Accessories</b>
OT-REFB-30	reference sphere, diameter = 30 mm
W&B-CSRP	package for surface coating comprising 2 x coating spray W&B-CSG, 1 x remover W&B-RSG

# OTM Series

The OTM series of optical sensors are available in different models, depending on measurement range and standoff requirements. For extremely high data acquisition rates (10 kHz), the OTM3-SA version is available as a pure analog unit with a specially adapted controller unit.

- OTM3/OTM3M
- OTM3A
- OTM3B
- OTM3S

## Optical System

- transmitter and receiver optics in co-axial arrangement
- semiconductor laser in visible range (685 nm).  
The collimated laser beam exits the center of the sensor optics.
- receiver optics form a symmetrical ring around the transmitter optics
- reflections from object are averaged to calculate reliable distance values.

## Sensor Head Electronics

- modulation of laser intensity avoids influence of ambient light
- continuous control of laser power to maintain constant reflection, independent of surface
- fully digital data transmission allows use of twisted pair cable up to 50 m between sensor head and controller (not for the OTM3-SA)
- LED on sensor indicates "in-range" status

## Sensor Controller

Two versions are available:

- desktop or 19" rack mount
- plug-in card for PCI bus

The controller receives digital data from the sensor head and from it calculates distance values. The data is linearized and pre-processed before transmission of results to the machine controller.

## Interfaces

- automatic probe ID (OTM3M only)
- RS-232
- TTL parallel port
- PC-bus
- trigger / sync. port for synchronization with machine scales
- laser safety circuit

OTM3S - very small sensor with separate electronics for applications where space or weight are a challenge.



The Wolf & Beck triangulation system - 360° capturing of reflected light.

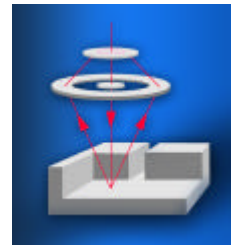

OTM3 / M - showing simple fixed link connection or use of automatic sensor identification option

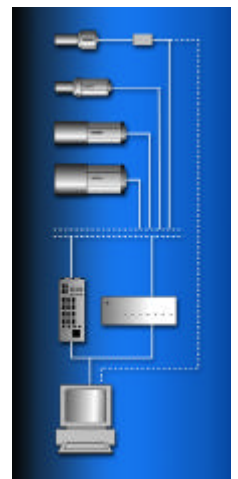

Highly structured surface digitized with an OTM sensor. Here a piece of leather - 10µm structures.



## Dr. Wolf & Beck GmbH

Daimlerstr. 19

73117 Wangen / Germany

Tel. +49 (0) 7161 1565-0

Fax +49 (0) 7161 1565-200

[www.wolfbeck.com](http://www.wolfbeck.com)